

Single Family Stairways

Properly installed stairways and handrails are an important feature to your home that provides support to prevent falls and creates a safe entrance and access to other levels in the home.

Dimensional tolerances

The largest tread depth or riser height within any stairway must not exceed the smallest by more than 3/8 inch.

Headroom

Every stairway must have a headroom clearance of not less than 6 ft. 8 in. The clearance must be measured vertically from the sloped plan adjoining the tread nosing or from the floor surface of the landings.

Width

Stairways must not be less than 36 inches wide. The handrail may enter a maximum of 4 1/2 inches into this dimension. If placing two handrails on a stairway, maintain a minimum of 27 inches.

Illumination

All interior and exterior stairways must be illuminated at a minimum one foot candle.

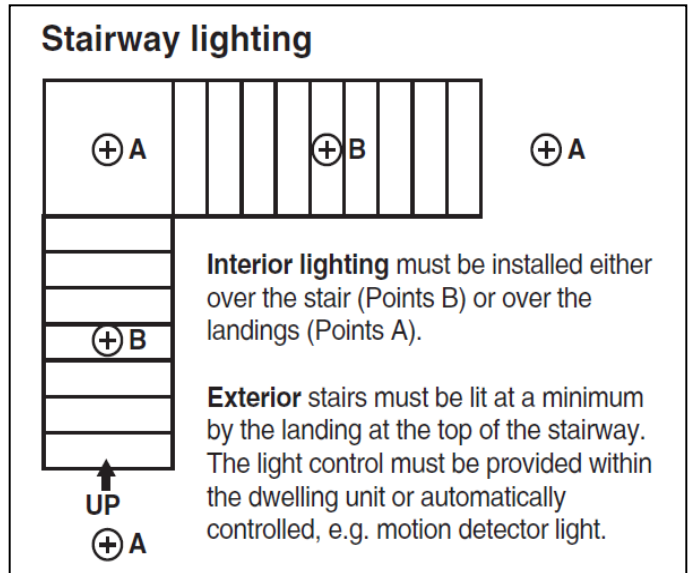
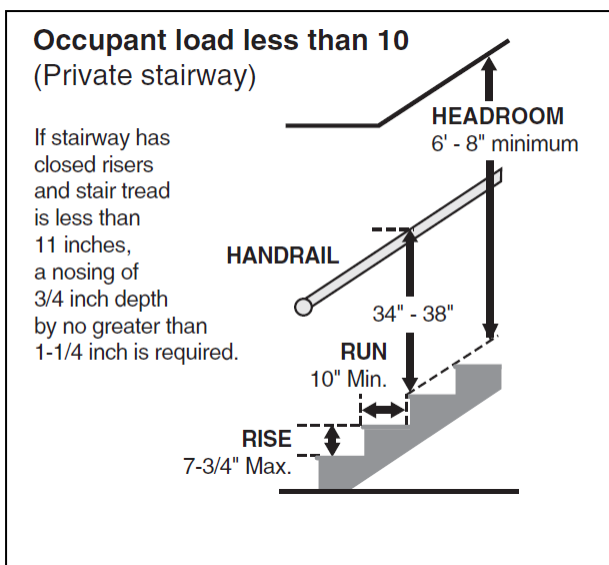

Risers

Open risers are permitted, provided that the opening between treads does not exceed 4 inches. This does not apply if less than 30

inches above floor or grade.

Handrails

Handrails are required at four or more risers. The top must be placed not less than 34 inches, or more than 38 inches above, the nosing of the treads. The ends must be returned or terminated in newel posts or safety terminals.

All required handrails must be continuous for the full length of the stairs from a point directly above the top riser of the flight to a point directly above the lowest riser of the flight.

Exceptions to the above requirements are:

- Handrails may be interrupted by a newel post at a turn.
- A volute, turnout or starting easing is allowed over the lowest tread.

The handgrips must not be less than 1 ¼ inches or more than 2 inches in cross-sectional dimension or the shape must provide an equivalent gripping surface. The handgrip must have a smooth surface with ends returned.

Guard opening limitations

